



"innovation in its most functional form"

PRODUCT DATA SHEET

FA1™

MECHANICAL FIXED FLANGE
ALIGNMENT TOOL

ALIGNING FORCE: = 1 T (10 kN)

TOOL WEIGHT = 1.6 kg (3.5 lbs)

KIT COMPONENTS

- 1 x FA1™ Tool
- 1 x Ratchet Strap
- 1 x Instruction Manual
- Product Code: FA1™STD



WEIGHTS AND DIMENSIONS

Tool Weight = 1.6 kg (3.5 lbs)
Gross Weight = 2 kg (4.4 lbs)

Box Dimensions:
170 x 360 x 155mm

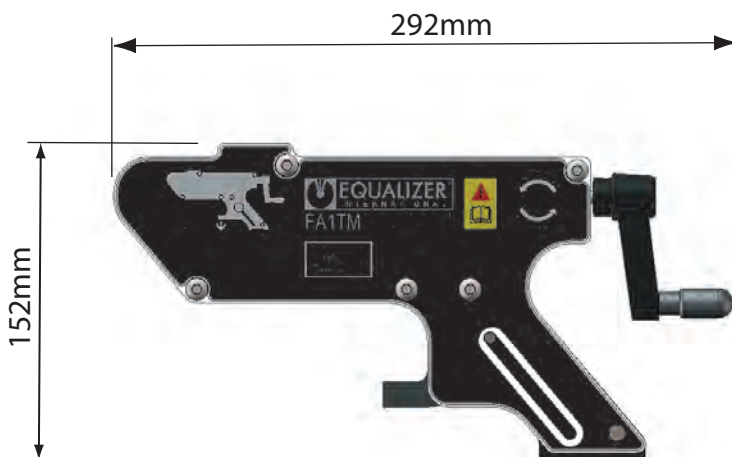

FA1™

HYDRAULIC FIXED FLANGE AND
ROTATIONAL ALIGNMENT TOOL



"innovation in its most functional form"

Minimum Extension

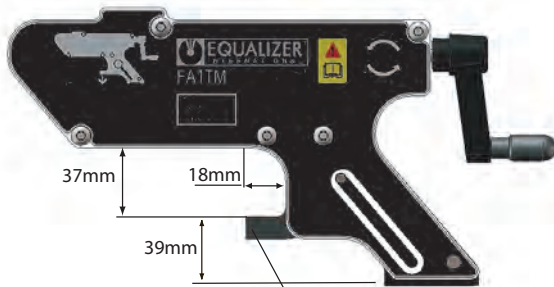

Maximum Extension

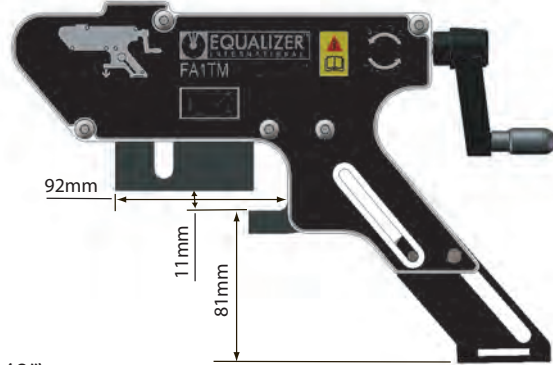

Minimum applicable Bolt Hole Diameter 16mm(0.63")

RANGE OF APPLICATION

ASME Weld neck

Class	150	300	400	600	900	1500	2500
Range	2" - 14"	1 1/2" - 6"	2" - 3 1/2"	1 1/2" - 3 1/2"	1 1/2" - 2"	1 1/2" - 1 1/2"	1 1/2" - 1"

DIN Weld neck

Class	PN16	PN25	PN40	PN64	PN100	PN160
Range	1 1/2" - 20"	1 1/2" - 12"	1 1/2" - 12"	1" - 5"	1" - 3"	1" - 2 1/2"

SPO compact Weld neck

Class	150	300
Range	16" - 34"	8" - 18"

BS10 Weld neck

Class	A	D	E	F	H
Range	8" - 42"	5" - 20"	7" - 22"	6" - 12"	6" - 12"

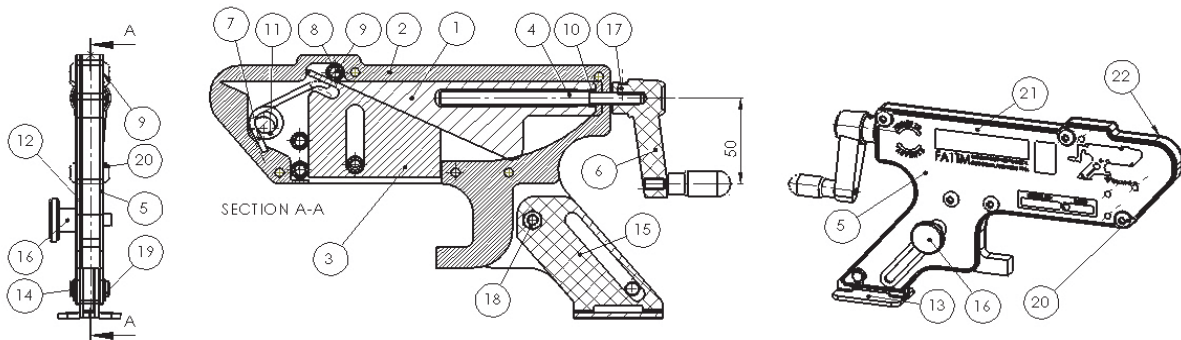

ITEM NO.	PART NO	DESCRIPTION	QTY.
1	210100-01	DRIVING WEDGE	1
2	210200-01	BODY FRAME	1
3	210300-01	DRIVEN WEDGE	1
4	210400-01	DRIVE SCREW	1
5	210500-01	COVER PLATE	2
6	210600-01	CRANK HANDLE	1
7	210800-01	TORSION SPRING	1
8	210900-01	NEEDLE BEARING	4
9	211100-01	BEARING SHAFT	4
10	211000-01	COLLAR	1
11	211200-01	SPRING MANDREL	1

ITEM NO.	PART NO	DESCRIPTION	QTY.
12	211600-01	DISTANCE PLATE	1
13	211800-01	DROP LEG	1
14	211900-01	LEG PIN 8MM	1
15	212200-01	LEG PLASTIC INSERT	1
16	230203-01	M6 RELEASE KNOB	1
17	300401-01	M5X6MM SCKT SET SCREW	1
18	771801-01	M6 HEX NUT	1
19	212000-01	SPRING RING 8MM	2
20	211700-01	M6X6 GR10.9 SCKT FL.BT.SCRW	10
21	070281-01	BODY PLATE STICKER RIGHT	1
22	070280-01	BODY PLATE STICKER LEFT	1